

HCD J-9K

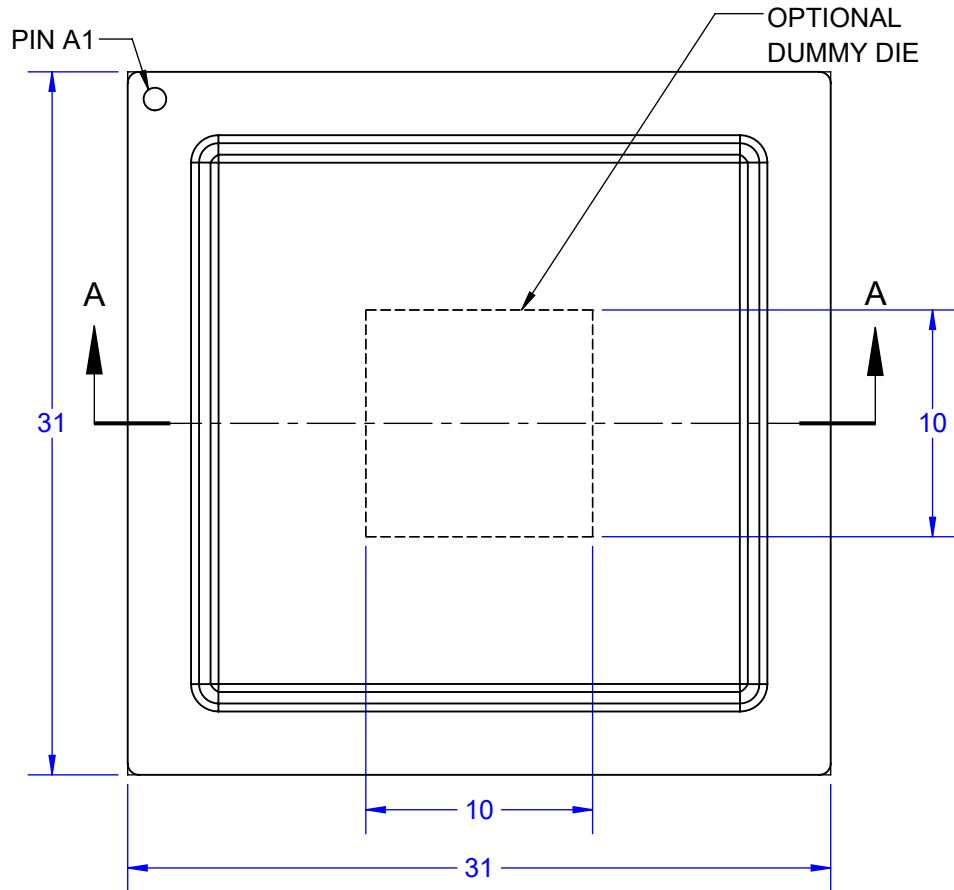

65 @J-9K

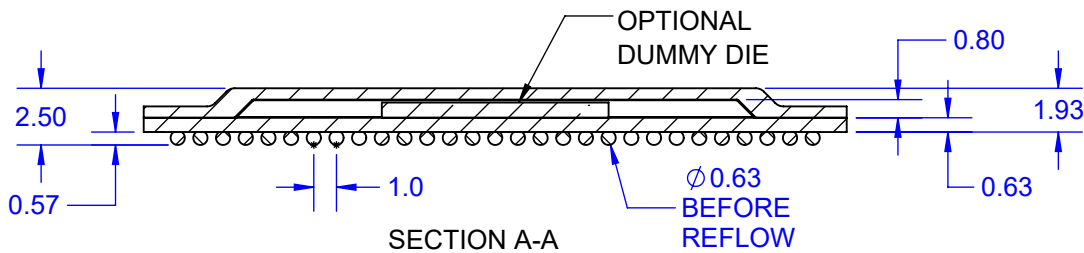
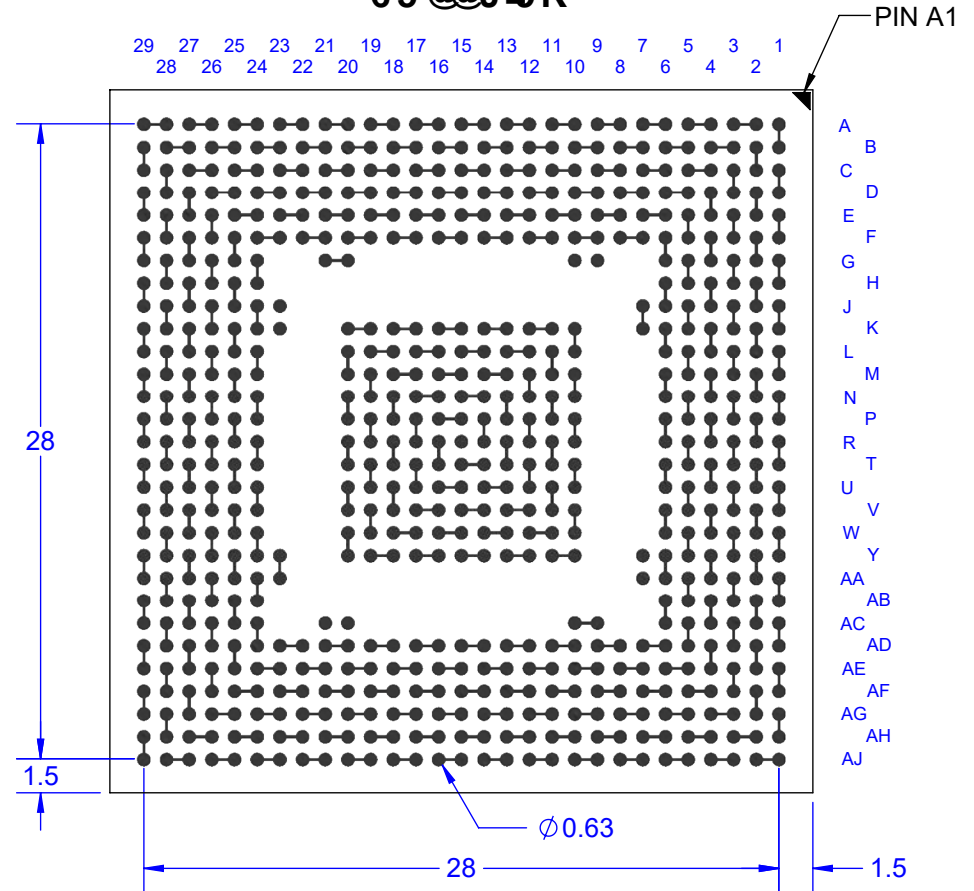

Notes: (Unless Otherwise Specified).

- 1) ALL DIMENSIONS ARE IN MM.
- 2) SOLDER BALL ALLOY: SEE PART NUMBER TABLE.
- 3) BALL DIAMETER (BEFORE REFLOW): 0.63mm (25 MIL).
- 4) SOLDER MASK DEFINED PAD OPENING: 0.50mm (19.7 MIL).
- 5) PAD Cu DIAMETER: 0.63mm (25 MIL).
- 6) SUBSTRATE MATERIAL: BT (ALTERNATIVE FR4).
- 7) DUMMY DIE IS OPTIONAL.
- 8) DAISY CHAIN PATTERN (SEE PAGE 2).
- 9) MSL-3 RECOMMENDED BAKING 24 HOURS @ 125°C TO REMOVE MOISTURE PRIOR SOLDERING TO PC BOARD.

D5FHBI A69FH56 @				
D5FHBI A69F	65 @25 @CM	DVI: F99	Fc < G	G] 8 9
SBGA689T1.0C-DC296D	Sn96.5/Ag3.0/Cu0.5	YES	YES	YES
SBGA689T1.0-DC296D	Sn63/Pb37	NO	NO	YES

APPROVALS	DATE	TopLine®			
DRAWN T.Au	4/30/2021				
ENG M. Hart	4/30/2021	TITLE SBGA689T1.0-DC296D DAISY CHAIN DUMMY			
MFG		SCALE 3:1	SIZE A	DRAWING NO. 512965	REV A
QA					
CUST		DO NOT SCALE DRAWING			SHEET 1 OF 9
REVISED					

65 @@J-K

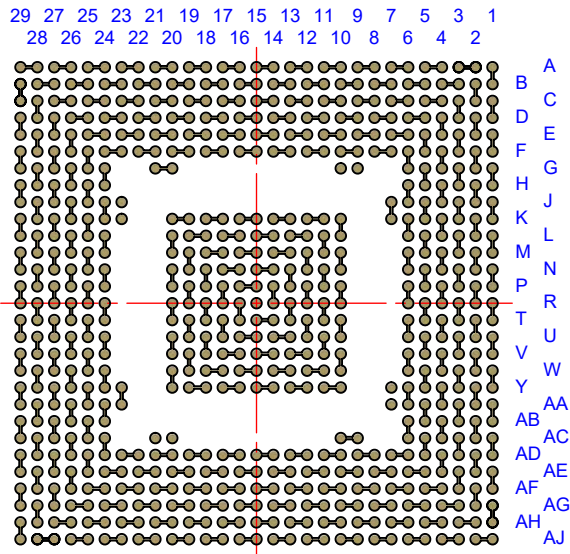

6 CHCA 'G-89 'fHCD'L!F5 MJ-K L

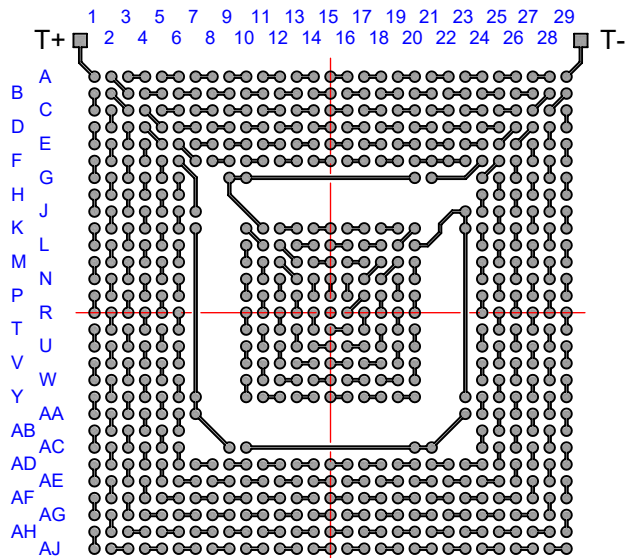
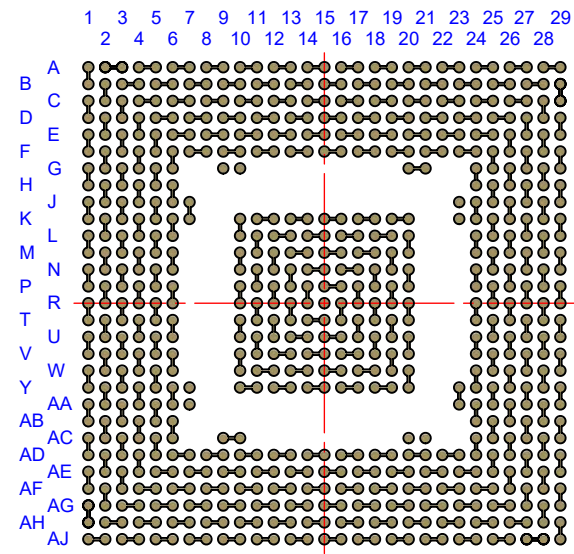

H9GH'J9<=7 @ '6 C5 F8

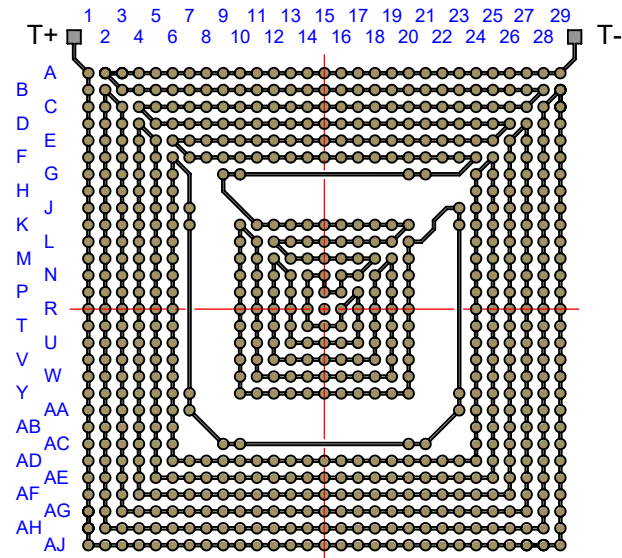

5: H9F'ACI BHB;

Notes:

- 1) PCB BOARD DIMENSIONS ARE PRESENTED ONLY AS A GUIDELINE. DESIGNERS SHOULD USE THEIR OWN EXPERIENCE WHEN DESIGNING PCB.
- 2) PCB Cu BALL PAD DIAMETER 0.63mm [25 MIL].
- 3) PCB DAISY CHAIN TRACING LINE WIDTH 0.20mm [8 MIL].
- 4) SMD (SOLDER MASK DEFINED) PAD OPENING: 0.5mm [19.7 MIL].



TITLE			
SBGA689T1.0-DC296D DAISY CHAIN DUMMY			
SCALE	SIZE	DRAWING NO.	REV
3:1	A	512965	A
DO NOT SCALE DRAWING			SHEET 2 OF 9

65 @@J→K

29 27 25 23 21 19 17 15 13 11 9 7 5 3 1
 28 26 24 22 20 18 16 14 12 10 8 6 4 2

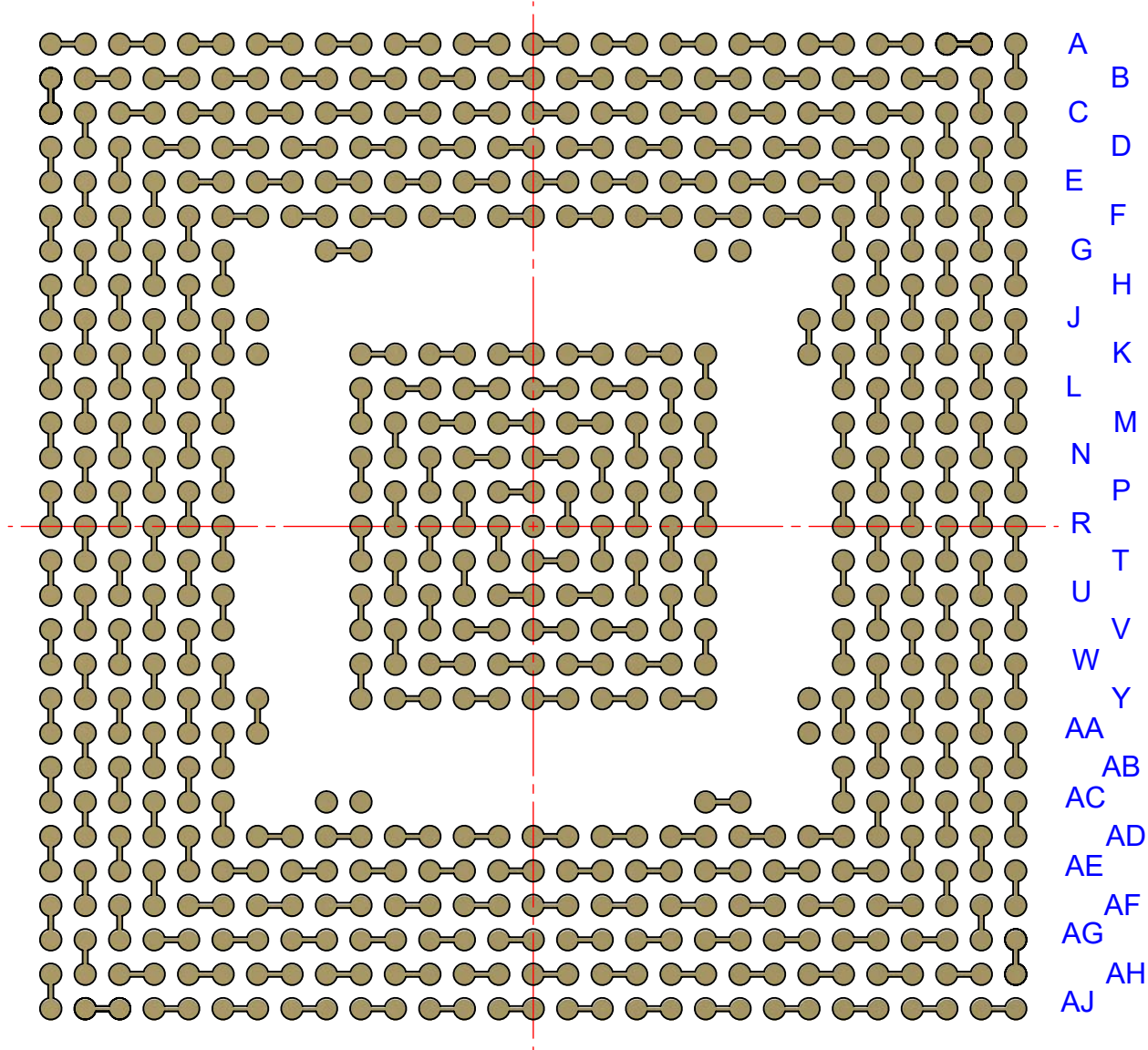

TopLine[®]			
TITLE		SBGA689T1.0-DC296D DAISY CHAIN DUMMY	
SCALE	SIZE	DRAWING NO.	REV
3:1	A	512965	A
DO NOT SCALE DRAWING			SHEET 3 OF 9

6 CHHCA 'G-8 9 'fHCD'L!F5 MJ-9K Ł

1 3 5 7 9 11 13 15 17 19 21 23 25 27 29
 2 4 6 8 10 12 14 16 18 20 22 24 26 28

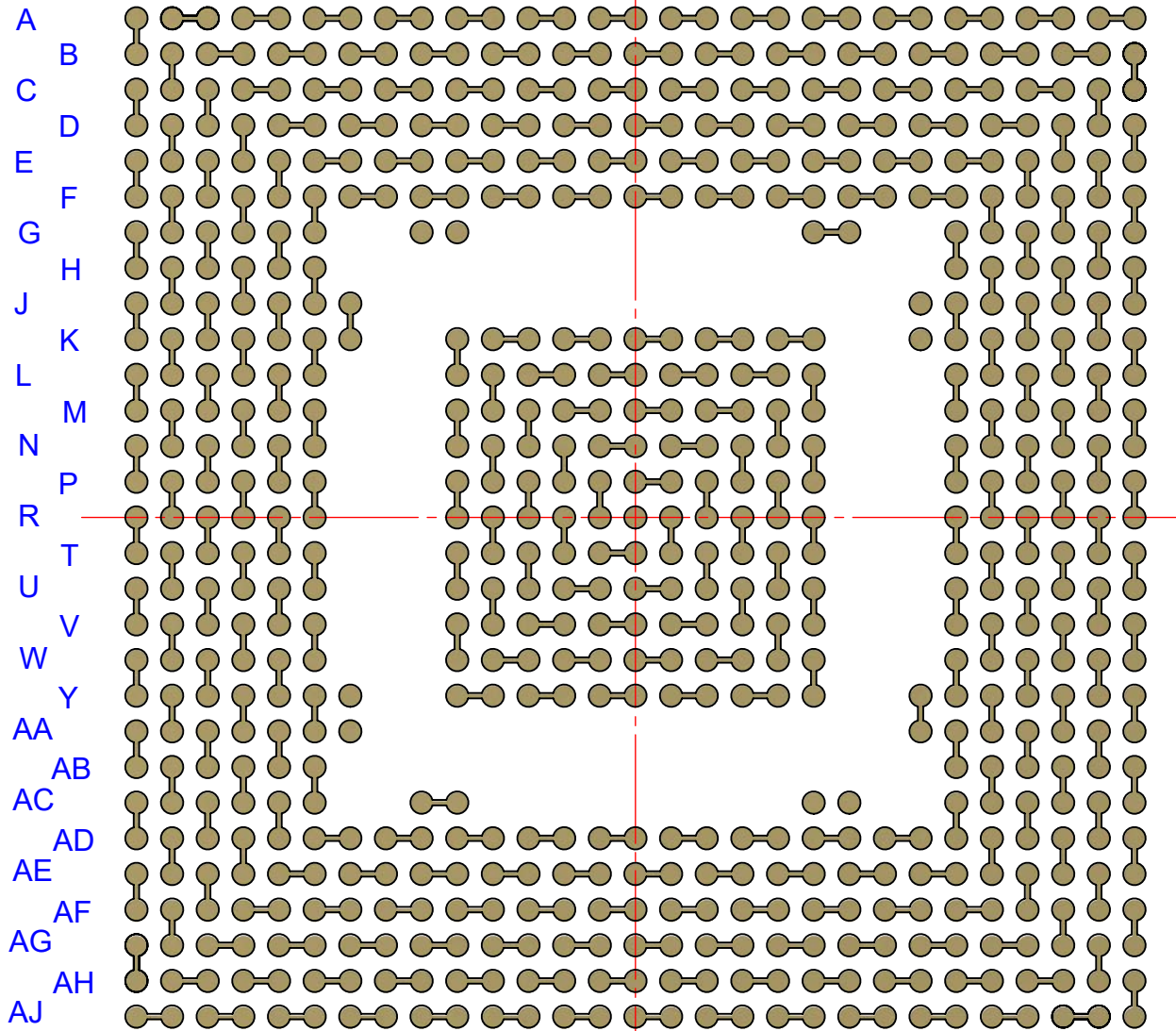

TopLine®			
TITLE SBGA689T1.0-DC296D DAISY CHAIN DUMMY			
SCALE 3:1	SIZE A	DRAWING NO. 512965	REV A
DO NOT SCALE DRAWING			SHEET 4 OF 9

H9GH'J9<7 @ '6 C5 F8

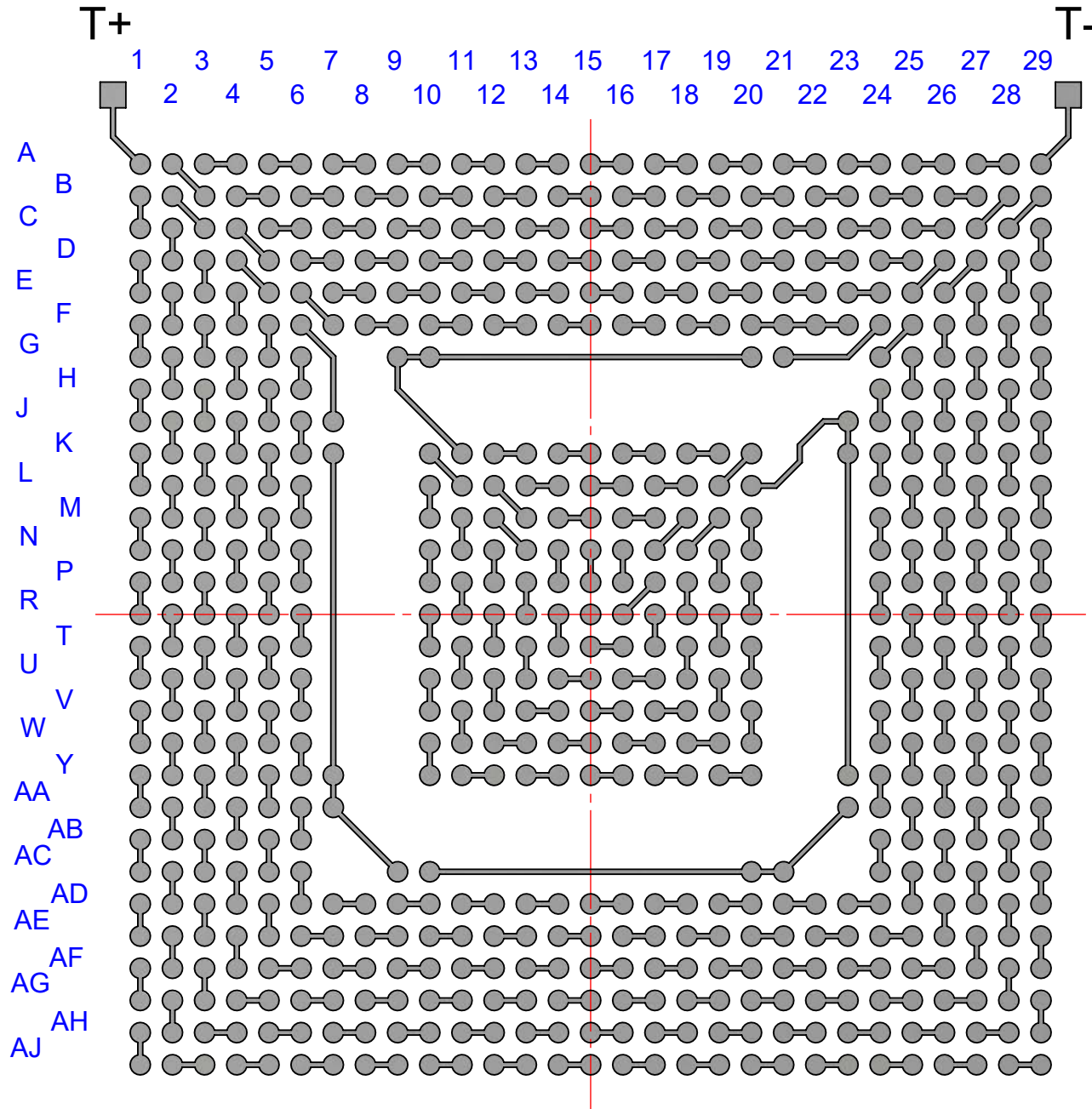

TopLine®			
TITLE SBGA689T1.0-DC296D DAISY CHAIN DUMMY			
SCALE 3:1	SIZE A	DRAWING NO. 512965	REV A
DO NOT SCALE DRAWING			SHEET 5 OF 9

5 : H9F`ACI BH-B;

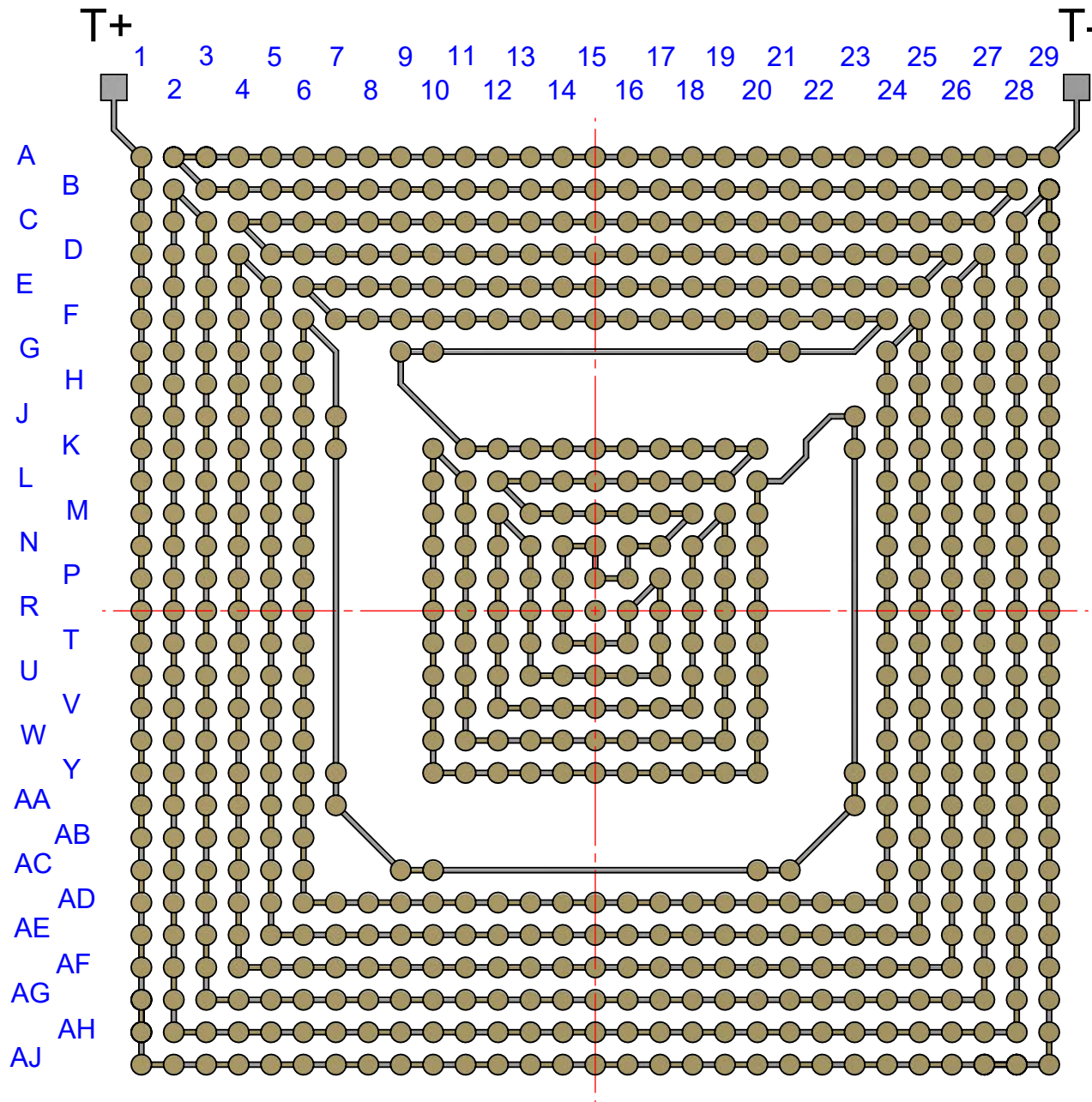

TopLine®			
TITLE SBGA689T1.0-DC296D DAISY CHAIN DUMMY			
SCALE 3:1	SIZE A	DRAWING NO. 512965	REV A
DO NOT SCALE DRAWING			SHEET 6 OF 9

<95 H'GDF9589F

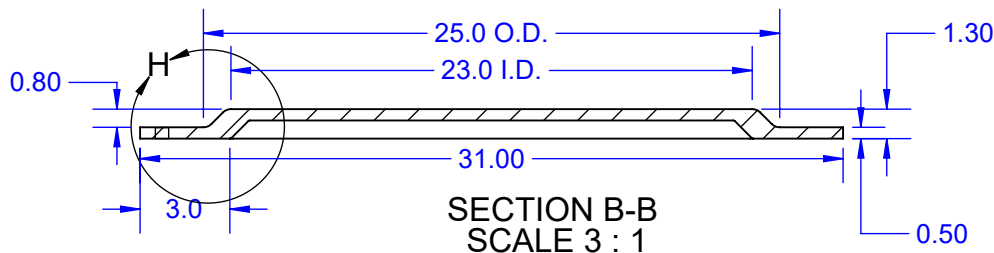
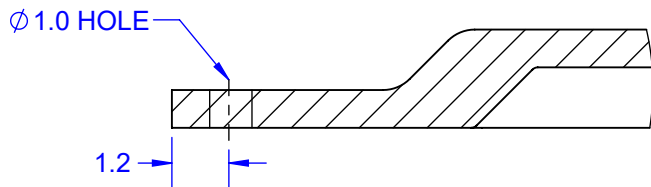
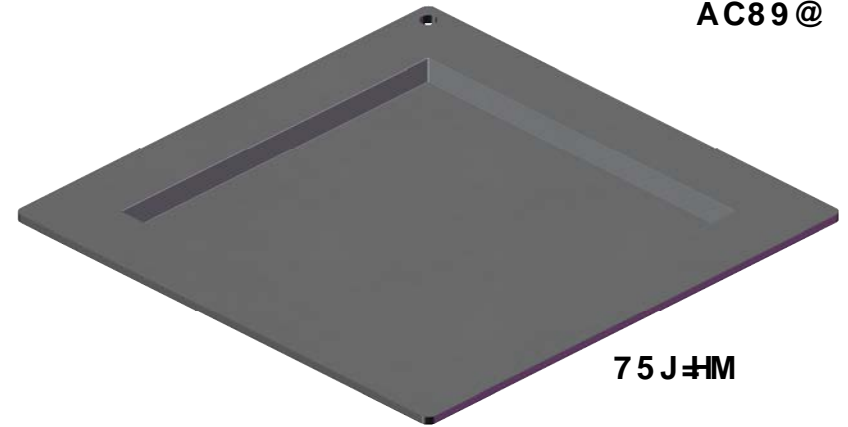
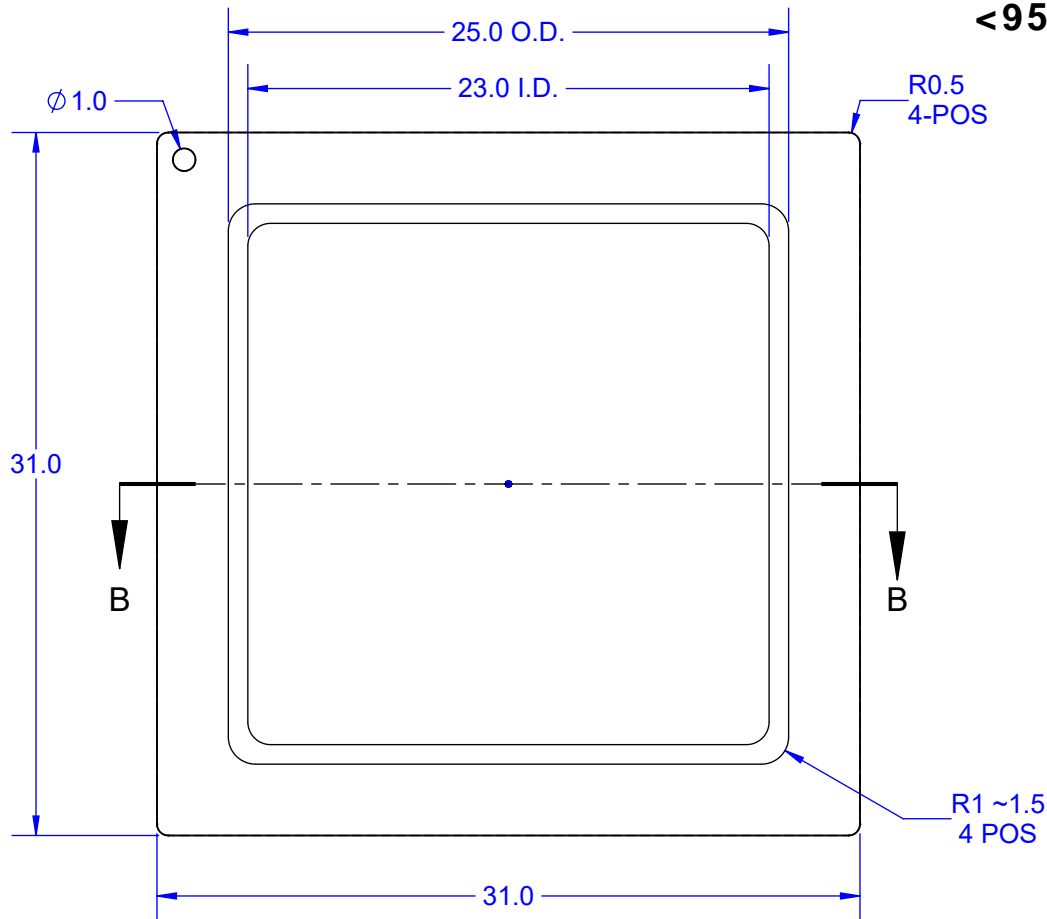

NOTES:

1. DIMENSION in MM
2. MATERIAL: COPPER ALLOY C1020 OR C1100 HALF HARD, OXYGEN FREE
3. PLATING: NICKEL 5um MIN (SEMI FINISH)

TopLine®			
TITLE SBGA689T1.0-DC296D DAISY CHAIN DUMMY			
SCALE 3:1	SIZE A	DRAWING NO. 512965	REV A
DO NOT SCALE DRAWING		SHEET 7 OF 9	

AC89@

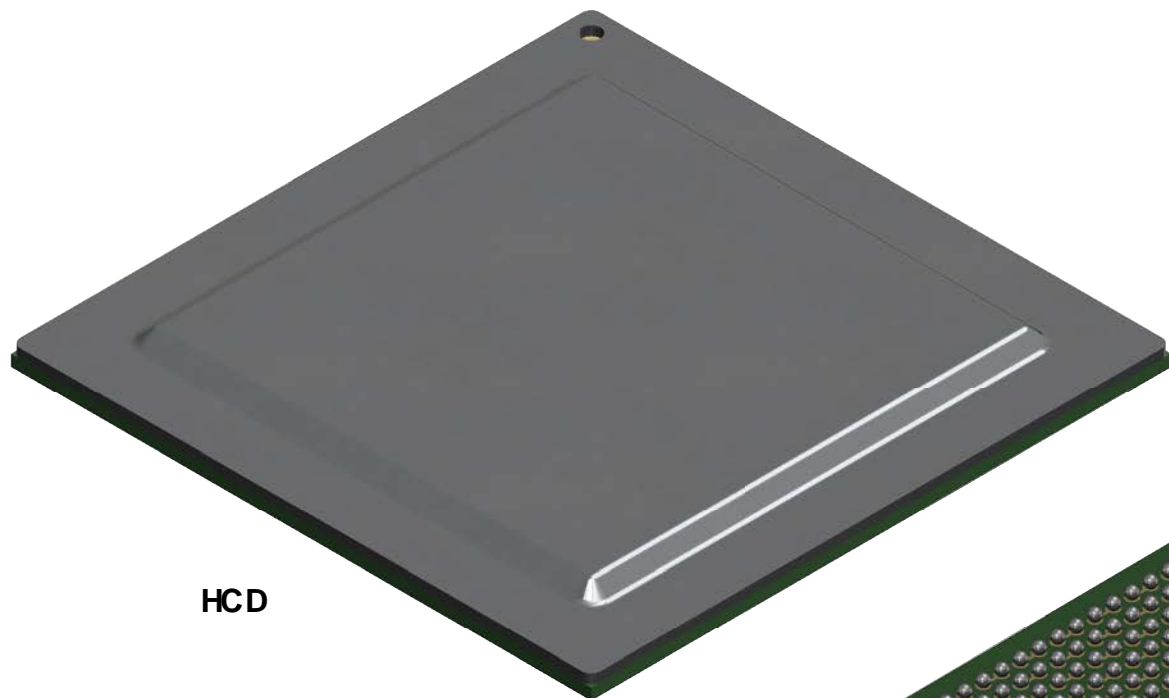

HCD

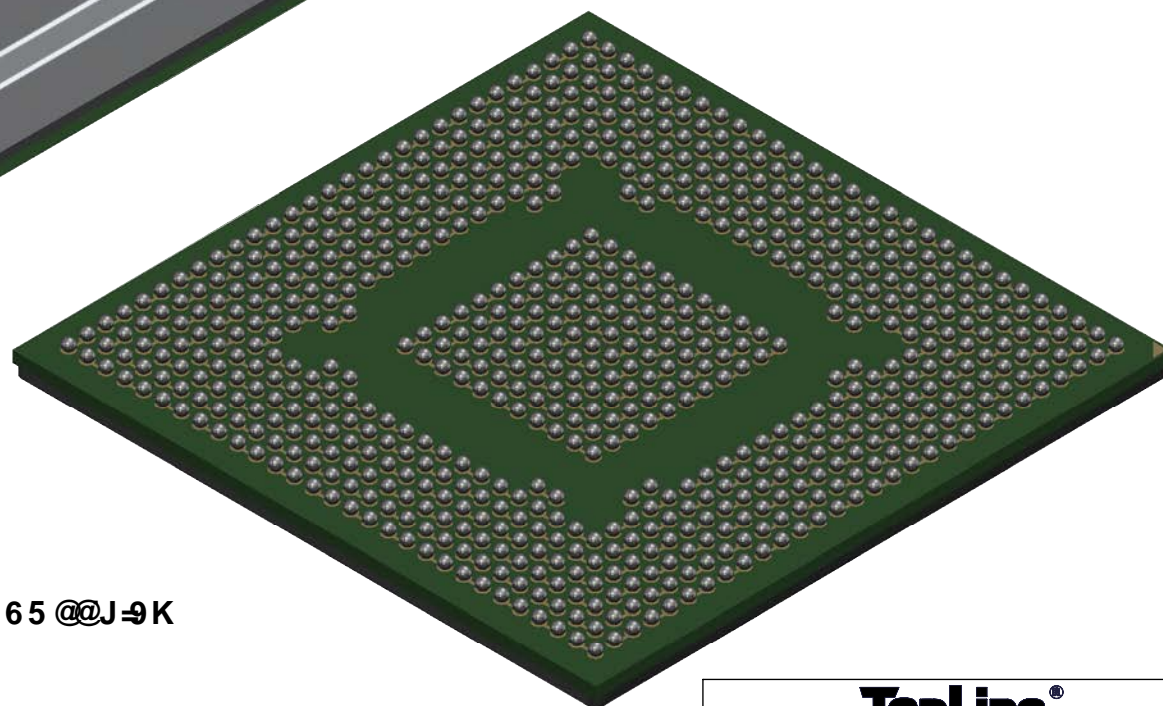

65 @@J-9K

TopLine®			
TITLE SBGA689T1.0-DC296D DAISY CHAIN DUMMY			
SCALE 3:1	SIZE A	DRAWING NO. 512965	REV A
DO NOT SCALE DRAWING			SHEET 8 OF 9

6 CHHCA GC @ 9F A5 G?
 *****fF < H'F958 B; L

29 27 25 23 21 19 17 15 13 11 9 7 5 3 1
 28 26 24 22 20 18 16 14 12 10 8 6 4 2

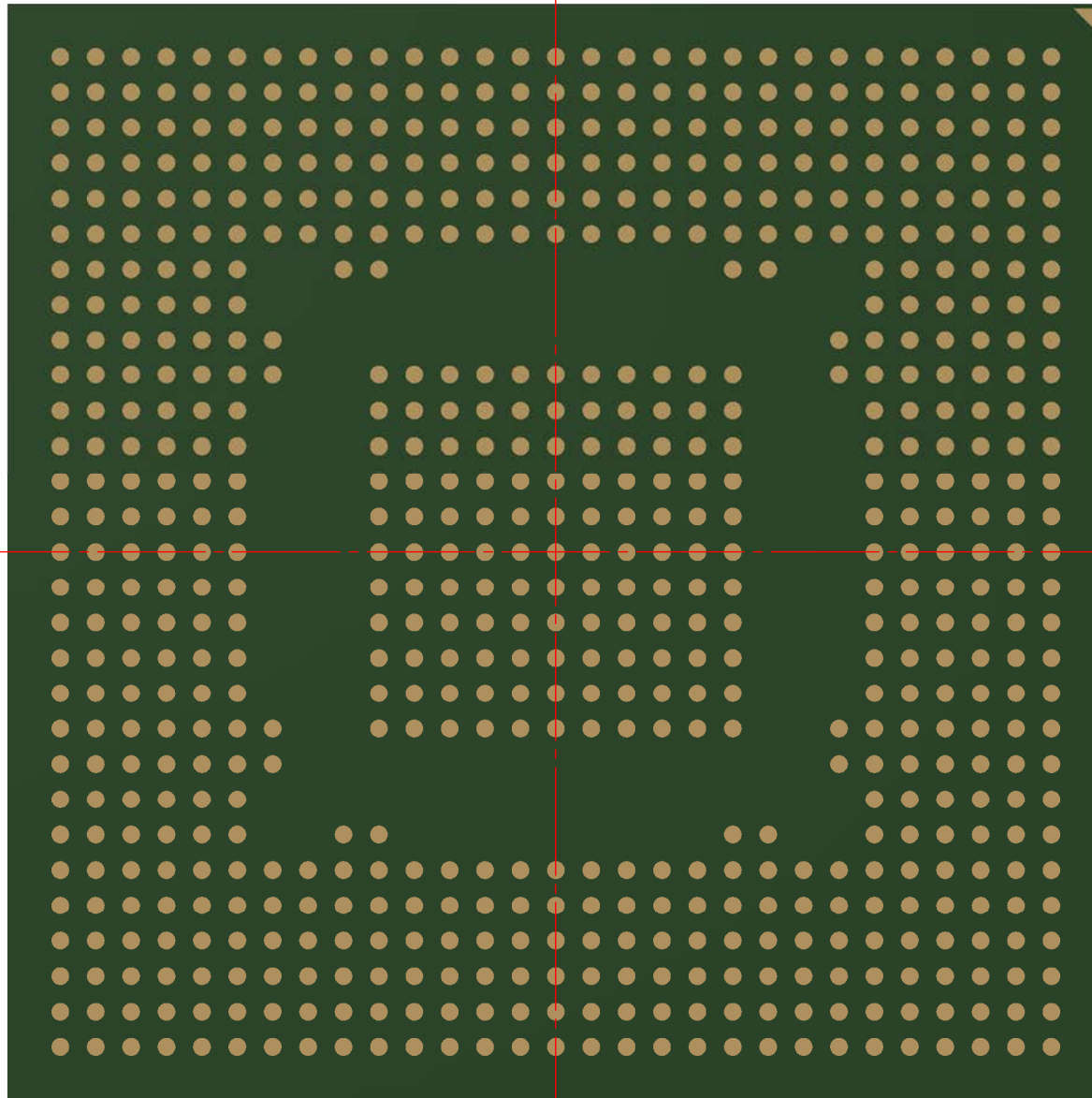

A
B
C
D
E
F
G
H
J
K
L
M
N
P
R
T
U
V
W
Y
AA
AB
AC
AD
AE
AF
AG
AH
AJ

TopLine®			
TITLE SBGA689T1.0-DC296D DAISY CHAIN DUMMY			
SCALE 3:1	SIZE A	DRAWING NO. 512965	REV A
DO NOT SCALE DRAWING			SHEET 9 OF 9